

**NOTICE!!**

**These documents have been scanned!**

**Do not place un-scanned documents beneath this notice!**

**Do not remove this notice from this file!**

GPO Jacket No. 560-102  
Print Order 61540  
Rise Business Services, LLC  
Job=AZ15 5/9/2019



Box Number= AZ15028



Claim Begin-End: AMC430837-AMC430837

1 Initial Receipt



AZ15028-11

AMC430583-AMC430889



**United States Department of the Interior**  
**Bureau of Land Management**  
LANDS/RECREATION & PLANNING  
ONE N CENTRAL AVE  
PHOENIX, AZ 85004 -2203  
Phone: 602-417-9200

Receipt

No: 3267210

<b>Transaction #:</b> 3362824	
<b>Date of Transaction:</b> 04/06/2015	
CUSTOMER:	
VIRGIL BAKER 6790 S OAKMONT DR CHANDLER, AZ 85249-8679 US	

ENTERED  
APR 10 2015  
BY: RAM

LINE #	QTY	DESCRIPTION	REMARKS	UNIT PRICE	TOTAL
1	1.00	LOCATABLE MINERALS / MINING CLAIMS-NEW, UNADJUD, ONE OR MORE AUTH NOS / NEW MINING CLAIMS LOCATION FEE CASES: AMC430837/\$37.00		- n/a -	37.00
2	1.00	LOCATABLE MINERALS / MINING CLAIMS-NEW, UNADJUD, ONE OR MORE AUTH NOS / NEW MINING CLAIM PROCESSING FEE CASES: AMC430837/\$20.00		- n/a -	20.00
3	1.00	LOCATABLE MINERALS / MINING CLAIMS-NEW, UNADJUD, ONE OR MORE AUTH NOS / NEW MINING CLAIMS MAINTENANCE FEE CASES: AMC430837/\$155.00		- n/a -	155.00
4	1.00	LOCATABLE MINERALS / MINING CLAIMS-NOT NEW-UNADJUD, ONE AUTH NO. ONLY / MINING CLAIM MONEY RECEIVED CASES: AMC430837/\$465.00	NEW ASSOC PLACER LOCATION	- n/a -	465.00
<b>TOTAL:</b>					<b>\$677.00</b>

PAYMENT INFORMATION			
1	AMOUNT:	677.00	POSTMARKED: N/A
	TYPE:	CHECK	RECEIVED: 04/06/2015
	CHECK NO:	1315	
	NAME:	BAKER, VIRGIL 6790 S OAKMONT DR	

4/6/2015

CHANDLER AZ 85249-8679 US

REMARKS

This receipt was generated by the automated BLM Collections and Billing System and is a paper representation of a portion of the official electronic record contained therein.



**NOTICE!!**

**These documents have been scanned!**

**Do not place un-scanned documents beneath this notice!**

**Do not remove this notice from this file!**

GPO Jacket No. 560-102  
Print Order 61540  
Rise Business Services, LLC  
Job=AZ15 5/9/2019



Box Number= AZ15028



Claim Begin-End: AMC430837-AMC430837

2 Correspondence



AZ15028-11

AMC430583-AMC430889

U.S. Postal Service™  
CERTIFIED MAIL™ RECEIPT

(Domestic Mail Only; No Insurance Coverage Provided)

For delivery information visit our website at [www.usps.com](http://www.usps.com)®

OFFICIAL USE

RECEIVED

BLM AZ STATE OFFICE

2015 JUL 21 P 4:23

Postmark  
Here

PHOENIX, ARIZONA

Postage

\$

Certified Fee

Return Receipt Fee  
(Endorsement Required)

Restricted Delivery Fee  
(Endorsement Required)

Total Postage

PATTI WOOLDRIDGE

1020 E SADDLE BUTTE ST

APACHE JUNCTION, AZ 85119-9875

9310/RM/AMC430837

Sent To

Street, Apt. No.,  
or PO Box No.

City, State, ZIP+

7014 0150 0000 5427 8642

## Certified Mail Provides:

- A mailing receipt
- A unique identifier for your mailpiece
- A record of delivery kept by the Postal Service for two years

### *Important Reminders:*

- Certified Mail may **ONLY** be combined with First-Class Mail® or Priority Mail®.
- Certified Mail is *not* available for any class of international mail.
- **NO INSURANCE COVERAGE IS PROVIDED** with Certified Mail. For valuables, please consider Insured or Registered Mail.
- For an additional fee, a *Return Receipt* may be requested to provide proof of delivery. To obtain Return Receipt service, please complete and attach a Return Receipt (PS Form 3811) to the article and add applicable postage to cover the fee. Endorse mailpiece "Return Receipt Requested". To receive a fee waiver for a duplicate return receipt, a USPS® postmark on your Certified Mail receipt is required.
- For an additional fee, delivery may be restricted to the addressee or addressee's authorized agent. Advise the clerk or mark the mailpiece with the endorsement "*Restricted Delivery*".
- If a postmark on the Certified Mail receipt is desired, please present the article at the post office for postmarking. If a postmark on the Certified Mail receipt is not needed, detach and affix label with postage and mail.

**IMPORTANT: Save this receipt and present it when making an inquiry.**

**SENDER: COMPLETE THIS SECTION**

- Complete items 1, 2, and 3. Also complete item 4 if Restricted Delivery is desired.
- Print your name and address on the reverse so that we can return the card to you.
- Attach this card to the back of the mailpiece, or on the front if space permits.

1. Article Addressed to:

PATTI WOOLDRIDGE  
 1020 E SADDLE BUTTE ST  
 APACHE JUNCTION, AZ 85119-9875  
 9310/RM/AMC430837

2. Article Number

*(Transfer from service label)*

7014 0150 0000 5427 8642

**COMPLETE THIS SECTION ON DELIVERY**

A. Signature

X

Patti Wooldridge

 Agent Addressee

B. Received by (Printed Name)

Patti Wooldridge

C. Date of Delivery

7/24/15

D. Is delivery address different from item 1?  Yes No

If YES, enter delivery address below:

/ 2015 JUL 28 P 3:28

PHOENIX, ARIZONA

3. Service Type

 Certified Mail® Priority Mail Express™ Registered Return Receipt for Merchandise Insured Mail Collect on Delivery

4. Restricted Delivery? (Extra Fee)

 Yes



UNITED STATES POSTAL SERVICE

PHOENIX

AZ 852

24 JUL '15

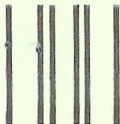

First-Class Mail  
Postage & Fees Paid  
USPS  
Permit No. G-10

- PM 91
- Sender: Please print your name, address, and ZIP+4® in this box•

**UNITED STATES  
DEPARTMENT OF THE INTERIOR  
Bureau of Land Management  
Arizona State Office  
One N. Central Avenue, Suite 800  
Phoenix, AZ 85004-4427**

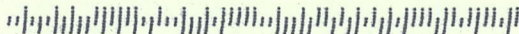



# United States Department of the Interior



BUREAU OF LAND MANAGEMENT

Arizona State Office

One North Central Avenue, Suite 800

Phoenix, Arizona 85004-4427

www.blm.gov/az/

**JUL 21 2015**

In Reply Refer To:

3800 (9310) RM

AMC430837

CERTIFIED MAIL – RETURN RECEIPT REQUESTED NO. 7014 0150 0000 5427 8642

## NOTICE

PATTI WOOLDRIDGE :  
1020 E SADDLE BUTTE ST :  
APACHE JUNCTION, AZ 85119-9875 :

This Notice Affects the Claims  
Shown in the Block Below.

---

AMC430837  
GOLDDIGGERS 6

---

### Locator Requirements for Association Placer Mining Claims Additional Information Required

The Bureau of Land Management (BLM) Arizona State Office received the location notice(s) for the association placer mining claim(s) listed above. You are included as a locator of the claim(s).

You must be qualified to locate an association placer mining claim and your mining claim must conform to the requirements of Federal law, 30 U.S.C. 35, 36, and regulations at 43 CFR 3832.22. These laws allow the location of placer mining claims greater than 20 acres so long as each of the locators has a bona fide interest in the claims, and has located the claims independently, for their own self-interest, and in good faith. The law is well established that a person cannot use the names of his friends, relatives, employees or club members as locators in order to locate for his own benefit a greater area of placer ground than is allowable by law. A company or corporation is considered to be one entity, entitled to locate claims of no more than 20 acres in size. Any claim located using dummy locators is not a valid mining claim.

By recording these location notices with the BLM you are representing to the United States government that you meet the qualifications for locating an association placer claim and that you are not using the names of other persons as dummy locators to locate more than 20 acres per claim for your own benefit. In accordance with 43 CFR 3830.9, if you file a document that you know contains false, erroneous, or fictitious information or statements, you may be subject to criminal penalties under 18 U.S.C. 1001 and 43 U.S.C. 1212. The maximum penalty is 5 years in prison and/or a fine of \$250,000.

In accordance with 43 CFR 1822.10, all documents required to be filed with the BLM must contain the applicant's (claimant's) legal name and current address. Additionally, 43 CFR 3833.11 (b)(2) requires that a certificate of location of a mining claim or site contain the names and current mailing addresses of the locators of the claim.

DOCUMENTS RECEIVED  
8/17/2015 RM

In accordance with 43 CFR 3830.3, an agent may locate mining claims on your behalf as long as they are duly constituted and appointed.

Before we can complete the recordation of your association placer mining claims, we will need the following information:

1. A signed and notarized statement from each claimant that says: "I (enter claimant's name) authorized and am aware that I am listed as a locator on the location notice for AMC (enter claim numbers). I have a bona fide interest in these claims and I located the claims independently, for my own self-interest and in good faith. I certify that these claims are in no way being located for the benefit of a company, corporation, or another individual in order to gain additional acreage they are not entitled to in accordance with the law."
2. A legal document from each claimant (such as a notarized power of attorney) showing that the person signing the location notice is acting on their behalf as their duly constituted and appointed agent or authorized representative. The Power of Attorney cannot be over 3 years old, meaning it must have been executed within the last 3 years.

The claimants of the above named mining claim(s) are hereby afforded 30 days from receipt of this Notice in which to furnish the requested information. Failure to do so will subject the recordation of these claims to further adjudication which may result in a partial rejection of the recordation and a reduction in acreage claimed.

If, after reviewing the information in this letter you determine that you do not, in fact, qualify to locate an association placer mining claim, please relinquish the association placer mining claims and relocate as an individual placer mining claim under 43 CFR 3832.22(b).

In accordance with 43 CFR 3833.33, you may transfer, sell, or otherwise convey an association placer mining claim at any time to an equal or greater number of mining claimants. If you want to transfer an association placer claim to an individual or an association that is smaller in number than the association that located the claim, a) you must have discovered a valuable mineral deposit before the transfer (documentation will be requested); or b) upon notice from the BLM, you must reduce the acreage of the claim, if necessary, so that you meet the 20-acre per locator limit. Per 43 CFR 3830.5, a discovery means that you have found a valuable mineral deposit. Any association placer claim transferred that does not meet these requirements is not a valid mining claim.

If you have any questions please contact RéAnn Myers at 602-417-9413.

Sincerely,



for

Rebecca Heick  
Acting Deputy State Director  
Division of Lands and Minerals





# United States Department of the Interior



BUREAU OF LAND MANAGEMENT  
Arizona State Office  
One North Central Avenue, Suite 800  
Phoenix, Arizona 85004-4427  
www.blm.gov/az/

**JUL 21 2015**

In Reply Refer To:  
3800 (9310) RM  
AMC430837

CERTIFIED MAIL – RETURN RECEIPT REQUESTED NO. 7014 0150 0000 5453 1198

## NOTICE

ROBERT MONTPAS : This Notice Affects the Claims  
4301 E ATHERTON RD : Shown in the Block Below.  
BURTON, MI 48519-1439 :

---

AMC430837  
GOLDDIGGERS 6

---

### Locator Requirements for Association Placer Mining Claims Additional Information Required

The Bureau of Land Management (BLM) Arizona State Office received the location notice(s) for the association placer mining claim(s) listed above. You are included as a locator of the claim(s).

You must be qualified to locate an association placer mining claim and your mining claim must conform to the requirements of Federal law, 30 U.S.C. 35, 36, and regulations at 43 CFR 3832.22. These laws allow the location of placer mining claims greater than 20 acres so long as each of the locators has a bona fide interest in the claims, and has located the claims independently, for their own self-interest, and in good faith. The law is well established that a person cannot use the names of his friends, relatives, employees or club members as locators in order to locate for his own benefit a greater area of placer ground than is allowable by law. A company or corporation is considered to be one entity, entitled to locate claims of no more than 20 acres in size. Any claim located using dummy locators is not a valid mining claim.

By recording these location notices with the BLM you are representing to the United States government that you meet the qualifications for locating an association placer claim and that you are not using the names of other persons as dummy locators to locate more than 20 acres per claim for your own benefit. In accordance with 43 CFR 3830.9, if you file a document that you know contains false, erroneous, or fictitious information or statements, you may be subject to criminal penalties under 18 U.S.C. 1001 and 43 U.S.C. 1212. The maximum penalty is 5 years in prison and/or a fine of \$250,000.

In accordance with 43 CFR 1822.10, all documents required to be filed with the BLM must contain the applicant's (claimant's) legal name and current address. Additionally, 43 CFR 3833.11 (b)(2) requires that a certificate of location of a mining claim or site contain the names and current mailing addresses of the locators of the claim.

DOCUMENTS RECEIVED  
8/17/2015. PM



In accordance with 43 CFR 3830.3, an agent may locate mining claims on your behalf as long as they are duly constituted and appointed.

Before we can complete the recordation of your association placer mining claims, we will need the following information:

1. A signed and notarized statement from each claimant that says: "I (enter claimant's name) authorized and am aware that I am listed as a locator on the location notice for AMC (enter claim numbers). I have a bona fide interest in these claims and I located the claims independently, for my own self-interest and in good faith. I certify that these claims are in no way being located for the benefit of a company, corporation, or another individual in order to gain additional acreage they are not entitled to in accordance with the law."
2. A legal document from each claimant (such as a notarized power of attorney) showing that the person signing the location notice is acting on their behalf as their duly constituted and appointed agent or authorized representative. The Power of Attorney cannot be over 3 years old, meaning it must have been executed within the last 3 years.

The claimants of the above named mining claim(s) are hereby afforded 30 days from receipt of this Notice in which to furnish the requested information. Failure to do so will subject the recordation of these claims to further adjudication which may result in a partial rejection of the recordation and a reduction in acreage claimed.

If, after reviewing the information in this letter you determine that you do not, in fact, qualify to locate an association placer mining claim, please relinquish the association placer mining claims and relocate as an individual placer mining claim under 43 CFR 3832.22(b).

In accordance with 43 CFR 3833.33, you may transfer, sell, or otherwise convey an association placer mining claim at any time to an equal or greater number of mining claimants. If you want to transfer an association placer claim to an individual or an association that is smaller in number than the association that located the claim, a) you must have discovered a valuable mineral deposit before the transfer (documentation will be requested); or b) upon notice from the BLM, you must reduce the acreage of the claim, if necessary, so that you meet the 20-acre per locator limit. Per 43 CFR 3830.5, a discovery means that you have found a valuable mineral deposit. Any association placer claim transferred that does not meet these requirements is not a valid mining claim.

If you have any questions please contact RéAnn Myers at 602-417-9413.

Sincerely,

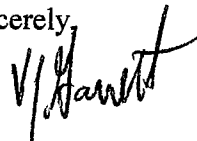

for

Rebecca Heick  
Acting Deputy State Director  
Division of Lands and Minerals



PLACE STICKER AT TOP OF ENVELOPE TO THE RIGHT  
OF THE RETURN ADDRESS, FOLD AT DOTTED LINE

**SENDER: COMPLETE THIS SECTION**

- Complete items 1, 2, and 3. Also complete item 4 if Restricted Delivery is desired.
- Print your name and address on the reverse so that we can return the card to you.
- Attach this card to the back of the mailpiece, or on the front if space permits.

1. Article Addressed to:

ROBERT MONTPAS  
 4301 E ATHERTON RD  
 BURTON, MI 48519-1439  
 9310/RM/AMC430837

2. Article Number  
 (Transfer from service label)

**COMPLETE THIS SECTION ON DELIVERY**

A. Signature

**X**

- Agent
- Addressee

B. Received by (Printed Name)

C. Date of Delivery

D. Is delivery address different from item 1?  Yes  
 If YES, enter delivery address below:  No

3. Service Type

- Certified Mail®
- Registered
- Insured Mail
- Priority Mail Express™
- Return Receipt for Merchandise
- Collect on Delivery

4. Restricted Delivery? (Extra Fee)

Yes

7014 0150 0000 5453 1198

U.S. Postal Service™

CERTIFIED MAIL™ RECEIPT

(Domestic Mail Only; No Insurance Coverage Provided)

For delivery information visit our website at [www.usps.com](http://www.usps.com)®

OFFICIAL USE

RECEIVED  
BLM AZ STATE OFFICE

2015 JUL 21 P 4:23  
Postmark Here

PHOENIX, ARIZONA

Postage \$

Certified Fee

Return Receipt Fee  
(Endorsement Required)

Restricted Delivery Fee  
(Endorsement Required)

Total Postage & Fees \$

Sent To

Street, Apt. No.,  
or PO Box No.

City, State, ZIP+

ROBERT MONTPAS  
4301 E ATHERTON RD  
BURTON, MI 48519-1439  
9310/RM/AMC430837

7014 0150 0000 5453 1198



## Certified Mail Provides:

- A mailing receipt
- A unique identifier for your mailpiece
- A record of delivery kept by the Postal Service for two years

### *Important Reminders:*

- Certified Mail may **ONLY** be combined with First-Class Mail® or Priority Mail®.
- Certified Mail is *not* available for any class of international mail.
- **NO INSURANCE COVERAGE IS PROVIDED** with Certified Mail. For valuables, please consider Insured or Registered Mail.
- For an additional fee, a *Return Receipt* may be requested to provide proof of delivery. To obtain Return Receipt service, please complete and attach a Return Receipt (PS Form 3811) to the article and add applicable postage to cover the fee. Endorse mailpiece "Return Receipt Requested". To receive a fee waiver for a duplicate return receipt, a USPS® postmark on your Certified Mail receipt is required.
- For an additional fee, delivery may be restricted to the addressee or addressee's authorized agent. Advise the clerk or mark the mailpiece with the endorsement "*Restricted Delivery*".
- If a postmark on the Certified Mail receipt is desired, please present the article at the post office for postmarking. If a postmark on the Certified Mail receipt is not needed, detach and affix label with postage and mail.

**IMPORTANT: Save this receipt and present it when making an inquiry.**

**SENDER: COMPLETE THIS SECTION**

- Complete items 1, 2, and 3. Also complete item 4 if Restricted Delivery is desired.
- Print your name and address on the reverse so that we can return the card to you.
- Attach this card to the back of the mailpiece, or on the front if space permits.

1. Article Addressed to:

LARRY KIVELA  
 4245 E LIBERTY LN  
 PHOENIX, AZ 85048-0537  
 9310/RM/AMC430837

2. Article Number  
 (Transfer from service label)

7014 0150 0000 5453 1204

PS Form 3811, July 2013

Domestic Return Receipt

**COMPLETE THIS SECTION ON DELIVERY**

A. Signature

\* *Dennis M Kivela*

- Agent  
 Addressee

B. Received by (Printed Name)

C. Date of Delivery

RECEIVED  
 BIRMINGHAM STATE OFFICE

7/27/2015

- D. Is delivery address different from Item 1?  Yes  
 If YES, enter delivery address below:  No

2015 JUL 29 P 4: 03

PHOENIX, ARIZONA

3. Service Type

- Certified Mail®     Priority Mail Express™  
 Registered     Return Receipt for Merchandise  
 Insured Mail     Collect on Delivery

4. Restricted Delivery? (Extra Fee)  Yes

UNITED STATES POSTAL SERVICE

AZ 852

27 JUL '15

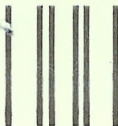

First-Class Mail  
Postage & Fees Paid  
USPS  
Permit No. G-10

PM 9 L

- Sender: Please print your name, address, and ZIP+4® in this box•

**UNITED STATES  
DEPARTMENT OF THE INTERIOR  
Bureau of Land Management  
Arizona State Office  
One N. Central Avenue, Suite 800  
Phoenix, AZ 85004-4427**

442700



U.S. Postal Service™  
CERTIFIED MAIL™ RECEIPT

(Domestic Mail Only; No Insurance Coverage Provided)

For delivery information visit our website at [www.usps.com](http://www.usps.com)®

OFFICIAL USE RECEIVED

BLM AZ STATE OFFICE

Postage \$

Certified Fee

2015 JUL 21 P 4: 23

Postmark  
Here

Return Receipt Fee  
(Endorsement Required)

Restricted Delivery Fee  
(Endorsement Required)

PHOENIX, ARIZONA

Total Postage & Fees \$

LARRY KIVELA

4245 E LIBERTY LN

PHOENIX, AZ 85048-0537

9310/RM/AMC430837

Sent To

Street, Apt. No.,  
or PO Box No.

City, State, ZIP+

7014 0150 0000 5455 1204  
402T 5545 0000 0510 4102

## Certified Mail Provides:

- A mailing receipt
- A unique identifier for your mailpiece
- A record of delivery kept by the Postal Service for two years

### ***Important Reminders:***

- Certified Mail may **ONLY** be combined with First-Class Mail® or Priority Mail®.
- Certified Mail is *not* available for any class of international mail.
- **NO INSURANCE COVERAGE IS PROVIDED** with Certified Mail. For valuables, please consider Insured or Registered Mail.
- For an additional fee, a *Return Receipt* may be requested to provide proof of delivery. To obtain Return Receipt service, please complete and attach a Return Receipt (PS Form 3811) to the article and add applicable postage to cover the fee. Endorse mailpiece "Return Receipt Requested". To receive a fee waiver for a duplicate return receipt, a USPS® postmark on your Certified Mail receipt is required.
- For an additional fee, delivery may be restricted to the addressee or addressee's authorized agent. Advise the clerk or mark the mailpiece with the endorsement "*Restricted Delivery*".
- If a postmark on the Certified Mail receipt is desired, please present the article at the post office for postmarking. If a postmark on the Certified Mail receipt is not needed, detach and affix label with postage and mail.

**IMPORTANT: Save this receipt and present it when making an inquiry.**





# United States Department of the Interior



BUREAU OF LAND MANAGEMENT  
Arizona State Office  
One North Central Avenue, Suite 800  
Phoenix, Arizona 85004-4427  
www.blm.gov/az/

**JUL 21 2015**

In Reply Refer To:  
3800 (9310) RM  
AMC430837

CERTIFIED MAIL – RETURN RECEIPT REQUESTED NO. 7014 0150 0000 5453 1204

## NOTICE

LARRY KIVELA : This Notice Affects the Claims  
4245 E LIBERTY LN : Shown in the Block Below.  
PHOENIX, AZ 85048-0537 :

---

AMC430837  
GOLDDIGGERS 6

---

### Locator Requirements for Association Placer Mining Claims Additional Information Required

The Bureau of Land Management (BLM) Arizona State Office received the location notice(s) for the association placer mining claim(s) listed above. You are included as a locator of the claim(s).

You must be qualified to locate an association placer mining claim and your mining claim must conform to the requirements of Federal law, 30 U.S.C. 35, 36, and regulations at 43 CFR 3832.22. These laws allow the location of placer mining claims greater than 20 acres so long as each of the locators has a bona fide interest in the claims, and has located the claims independently, for their own self-interest, and in good faith. The law is well established that a person cannot use the names of his friends, relatives, employees or club members as locators in order to locate for his own benefit a greater area of placer ground than is allowable by law. A company or corporation is considered to be one entity, entitled to locate claims of no more than 20 acres in size. Any claim located using dummy locators is not a valid mining claim.

By recording these location notices with the BLM you are representing to the United States government that you meet the qualifications for locating an association placer claim and that you are not using the names of other persons as dummy locators to locate more than 20 acres per claim for your own benefit. In accordance with 43 CFR 3830.9, if you file a document that you know contains false, erroneous, or fictitious information or statements, you may be subject to criminal penalties under 18 U.S.C. 1001 and 43 U.S.C. 1212. The maximum penalty is 5 years in prison and/or a fine of \$250,000.

In accordance with 43 CFR 1822.10, all documents required to be filed with the BLM must contain the applicant's (claimant's) legal name and current address. Additionally, 43 CFR 3833.11 (b)(2) requires that a certificate of location of a mining claim or site contain the names and current mailing addresses of the locators of the claim.

DOCUMENTS RECEIVED  
7/17/2015. PAW

In accordance with 43 CFR 3830.3, an agent may locate mining claims on your behalf as long as they are duly constituted and appointed.

Before we can complete the recordation of your association placer mining claims, we will need the following information:

1. A signed and notarized statement from each claimant that says: "I (enter claimant's name) authorized and am aware that I am listed as a locator on the location notice for AMC (enter claim numbers). I have a bona fide interest in these claims and I located the claims independently, for my own self-interest and in good faith. I certify that these claims are in no way being located for the benefit of a company, corporation, or another individual in order to gain additional acreage they are not entitled to in accordance with the law."
2. A legal document from each claimant (such as a notarized power of attorney) showing that the person signing the location notice is acting on their behalf as their duly constituted and appointed agent or authorized representative. The Power of Attorney cannot be over 3 years old, meaning it must have been executed within the last 3 years.

The claimants of the above named mining claim(s) are hereby afforded 30 days from receipt of this Notice in which to furnish the requested information. Failure to do so will subject the recordation of these claims to further adjudication which may result in a partial rejection of the recordation and a reduction in acreage claimed.

If, after reviewing the information in this letter you determine that you do not, in fact, qualify to locate an association placer mining claim, please relinquish the association placer mining claims and relocate as an individual placer mining claim under 43 CFR 3832.22(b).

In accordance with 43 CFR 3833.33, you may transfer, sell, or otherwise convey an association placer mining claim at any time to an equal or greater number of mining claimants. If you want to transfer an association placer claim to an individual or an association that is smaller in number than the association that located the claim, a) you must have discovered a valuable mineral deposit before the transfer (documentation will be requested); or b) upon notice from the BLM, you must reduce the acreage of the claim, if necessary, so that you meet the 20-acre per locator limit. Per 43 CFR 3830.5, a discovery means that you have found a valuable mineral deposit. Any association placer claim transferred that does not meet these requirements is not a valid mining claim.

If you have any questions please contact RéAnn Myers at 602-417-9413.

Sincerely,

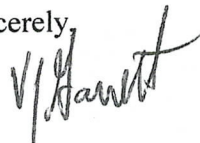

for

Rebecca Heick  
Acting Deputy State Director  
Division of Lands and Minerals

U.S. Postal Service™  
CERTIFIED MAIL™ RECEIPT

(Domestic Mail Only; No Insurance Coverage Provided)

For delivery information visit our website at [www.usps.com](http://www.usps.com)®

OFFICIAL USE

RECEIVED  
BLM AZ STATE OFFICE

Postage \$  
Certified Fee  
Return Receipt Fee  
(Endorsement Required)  
Restricted Delivery Fee  
(Endorsement Required)  
Total Postage & Fees \$

2015 JUL 21 P 4: 23

Postmark  
Here

PHOENIX, ARIZONA

Sent To

JERRY ALMOS

Street, Apt. No.,  
or PO Box No.

29 RIVER RD

City, State, ZIP+

CASCADE, MT 59421-8101

9310/RM/AMC430837

7014 0150 0000 5455 1297



## Certified Mail Provides:

- A mailing receipt
- A unique identifier for your mailpiece
- A record of delivery kept by the Postal Service for two years

### **Important Reminders:**

- Certified Mail may ONLY be combined with First-Class Mail<sup>®</sup> or Priority Mail<sup>®</sup>.
- Certified Mail is *not* available for any class of international mail.
- NO INSURANCE COVERAGE IS PROVIDED with Certified Mail. For valuables, please consider Insured or Registered Mail.
- For an additional fee, a *Return Receipt* may be requested to provide proof of delivery. To obtain Return Receipt service, please complete and attach a Return Receipt (PS Form 3811) to the article and add applicable postage to cover the fee. Endorse mailpiece "Return Receipt Requested". To receive a fee waiver for a duplicate return receipt, a USPS<sup>®</sup> postmark on your Certified Mail receipt is required.
- For an additional fee, delivery may be restricted to the addressee or addressee's authorized agent. Advise the clerk or mark the mailpiece with the endorsement "*Restricted Delivery*".
- If a postmark on the Certified Mail receipt is desired, please present the article at the post office for postmarking. If a postmark on the Certified Mail receipt is not needed, detach and affix label with postage and mail.

**IMPORTANT: Save this receipt and present it when making an inquiry.**

**SENDER: COMPLETE THIS SECTION**

- Complete items 1, 2, and 3. Also complete item 4 if Restricted Delivery is desired.
- Print your name and address on the reverse so that we can return the card to you.
- Attach this card to the back of the mailpiece, or on the front if space permits.

1. Article Addressed to:

JERRY ALMOS  
 29 RIVER RD  
 CASCADE, MT 59421-8101  
 9310/RM/AMC430837

2. Article Number

(Transfer from service label)

7014 0150 0000 5453 1297

PS Form 3811, July 2013

Domestic Return Receipt

**COMPLETE THIS SECTION ON DELIVERY**

A. Signature

X

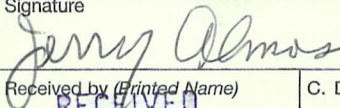
 Agent Addressee

B. Received by (Printed Name)

RECEIVED  
 BLM A7 STATE OFFICE

C. Date of Delivery

7/28/2015

D. Is delivery address different from item 1?  Yes NoIf YES, enter delivery address below:  No

2015 AUG -3 P 2:56

PHOENIX, ARIZONA

3. Service Type

 Certified Mail® Priority Mail Express™ Registered Return Receipt for Merchandise Insured Mail Collect on Delivery

4. Restricted Delivery? (Extra Fee)

 Yes



GREAT FALLS MT 594  
UNITED STATES POSTAL SERVICE

26 JUL 2015 PM 1 T

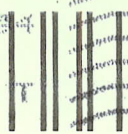

First-Class Mail  
Postage & Fees Paid  
USPS  
Permit No. G-10

• Sender: Please print your name, address, and ZIP+4® in this box•

UNITED STATES  
DEPARTMENT OF THE INTERIOR  
Bureau of Land Management  
Arizona State Office  
One N. Central Avenue, Suite 800  
Phoenix, AZ 85004-4427

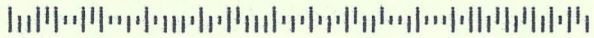



# United States Department of the Interior



BUREAU OF LAND MANAGEMENT

Arizona State Office

One North Central Avenue, Suite 800

Phoenix, Arizona 85004-4427

www.blm.gov/az/

JUL 21 2015

In Reply Refer To:

3800 (9310) RM

AMC430837

CERTIFIED MAIL – RETURN RECEIPT REQUESTED NO. 7014 0150 0000 5453 1297

## NOTICE

JERRY ALMOS

29 RIVER RD

CASCADE, MT 59421-8101

:  
:  
:

This Notice Affects the Claims  
Shown in the Block Below.

---

AMC430837

GOLDDIGGERS 6

---

### Locator Requirements for Association Placer Mining Claims Additional Information Required

The Bureau of Land Management (BLM) Arizona State Office received the location notice(s) for the association placer mining claim(s) listed above. You are included as a locator of the claim(s).

You must be qualified to locate an association placer mining claim and your mining claim must conform to the requirements of Federal law, 30 U.S.C. 35, 36, and regulations at 43 CFR 3832.22. These laws allow the location of placer mining claims greater than 20 acres so long as each of the locators has a bona fide interest in the claims, and has located the claims independently, for their own self-interest, and in good faith. The law is well established that a person cannot use the names of his friends, relatives, employees or club members as locators in order to locate for his own benefit a greater area of placer ground than is allowable by law. A company or corporation is considered to be one entity, entitled to locate claims of no more than 20 acres in size. Any claim located using dummy locators is not a valid mining claim.

By recording these location notices with the BLM you are representing to the United States government that you meet the qualifications for locating an association placer claim and that you are not using the names of other persons as dummy locators to locate more than 20 acres per claim for your own benefit. In accordance with 43 CFR 3830.9, if you file a document that you know contains false, erroneous, or fictitious information or statements, you may be subject to criminal penalties under 18 U.S.C. 1001 and 43 U.S.C. 1212. The maximum penalty is 5 years in prison and/or a fine of \$250,000.

In accordance with 43 CFR 1822.10, all documents required to be filed with the BLM must contain the applicant's (claimant's) legal name and current address. Additionally, 43 CFR 3833.11 (b)(2) requires that a certificate of location of a mining claim or site contain the names and current mailing addresses of the locators of the claim.

DOCUMENTS RECEIVED.

8/17/2015 km

In accordance with 43 CFR 3830.3, an agent may locate mining claims on your behalf as long as they are duly constituted and appointed.

Before we can complete the recordation of your association placer mining claims, we will need the following information:

1. A signed and notarized statement from each claimant that says: "I (enter claimant's name) authorized and am aware that I am listed as a locator on the location notice for AMC (enter claim numbers). I have a bona fide interest in these claims and I located the claims independently, for my own self-interest and in good faith. I certify that these claims are in no way being located for the benefit of a company, corporation, or another individual in order to gain additional acreage they are not entitled to in accordance with the law."
2. A legal document from each claimant (such as a notarized power of attorney) showing that the person signing the location notice is acting on their behalf as their duly constituted and appointed agent or authorized representative. The Power of Attorney cannot be over 3 years old, meaning it must have been executed within the last 3 years.

The claimants of the above named mining claim(s) are hereby afforded 30 days from receipt of this Notice in which to furnish the requested information. Failure to do so will subject the recordation of these claims to further adjudication which may result in a partial rejection of the recordation and a reduction in acreage claimed.

If, after reviewing the information in this letter you determine that you do not, in fact, qualify to locate an association placer mining claim, please relinquish the association placer mining claims and relocate as an individual placer mining claim under 43 CFR 3832.22(b).

In accordance with 43 CFR 3833.33, you may transfer, sell, or otherwise convey an association placer mining claim at any time to an equal or greater number of mining claimants. If you want to transfer an association placer claim to an individual or an association that is smaller in number than the association that located the claim, a) you must have discovered a valuable mineral deposit before the transfer (documentation will be requested); or b) upon notice from the BLM, you must reduce the acreage of the claim, if necessary, so that you meet the 20-acre per locator limit. Per 43 CFR 3830.5, a discovery means that you have found a valuable mineral deposit. Any association placer claim transferred that does not meet these requirements is not a valid mining claim.

If you have any questions please contact RéAnn Myers at 602-417-9413.

Sincerely,

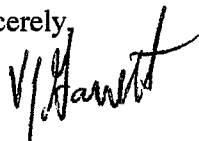

for

Rebecca Heick  
Acting Deputy State Director  
Division of Lands and Minerals

U.S. Postal Service™

# CERTIFIED MAIL™ RECEIPT

(Domestic Mail Only; No Insurance Coverage Provided)

For delivery information visit our website at [www.usps.com](http://www.usps.com)®

OFFICIAL USE  
RECEIVED  
BLM AZ STATE OFFICE

Postage \$  
Certified Fee  
Return Receipt Fee  
(Endorsement Required)  
Restricted Delivery Fee  
(Endorsement Required)  
Total Postage <sup>o</sup> \$500.00

2015 JUL 21 P 4: 23

Postmark  
Here

PHOENIX, ARIZONA

VIRGIL L BAKER

6790 S OAKMONT DR

CHANDLER, AZ 85249-8679

9310/RM/AMC430837

Sent To

Street, Apt. No.  
or PO Box No.

City, State, ZIP

7014 0150 0000 5455 0000 0510 4102



## Certified Mail Provides:

- A mailing receipt
- A unique identifier for your mailpiece
- A record of delivery kept by the Postal Service for two years

### ***Important Reminders:***

- Certified Mail may **ONLY** be combined with First-Class Mail<sup>®</sup> or Priority Mail<sup>®</sup>.
- Certified Mail is *not* available for any class of international mail.
- **NO INSURANCE COVERAGE IS PROVIDED** with Certified Mail. For valuables, please consider Insured or Registered Mail.
- For an additional fee, a *Return Receipt* may be requested to provide proof of delivery. To obtain Return Receipt service, please complete and attach a Return Receipt (PS Form 3811) to the article and add applicable postage to cover the fee. Endorse mailpiece "Return Receipt Requested". To receive a fee waiver for a duplicate return receipt, a USPS<sup>®</sup> postmark on your Certified Mail receipt is required.
- For an additional fee, delivery may be restricted to the addressee or addressee's authorized agent. Advise the clerk or mark the mailpiece with the endorsement "*Restricted Delivery*".
- If a postmark on the Certified Mail receipt is desired, please present the article at the post office for postmarking. If a postmark on the Certified Mail receipt is not needed, detach and affix label with postage and mail.

**IMPORTANT: Save this receipt and present it when making an inquiry.**

**SENDER: COMPLETE THIS SECTION****COMPLETE THIS SECTION ON DELIVERY**

- Complete items 1, 2, and 3. Also complete item 4 if Restricted Delivery is desired.
- Print your name and address on the reverse so that we can return the card to you.
- Attach this card to the back of the mailpiece, or on the front if space permits.

A. Signature

X

Virgil Baker

 Agent Addressee

B. Received by (Printed Name)

C. Date of Delivery

Virgil Baker 7-27-15

D. Is delivery address different from item 1?

 Yes No

If YES, enter delivery address below:

1. Article Addressed to:

VIRGIL L BAKER

6790 S OAKMONT DR

CHANDLER, AZ 85249-8679

9310/RM/AMC430837

RECEIVED  
BLM AZ STATE OFFICE

2015 JUL 31 P 2:51

PHOENIX, ARIZONA

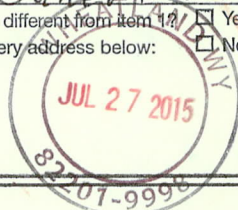

3. Service Type

 Certified Mail® Priority Mail Express™ Registered Return Receipt for Merchandise Insured Mail Collect on Delivery

4. Restricted Delivery? (Extra Fee)

 Yes

2. Article Number

(Transfer from service label)

7014 0150 0000 5453 1105

UNITED STATES POSTAL SERVICE

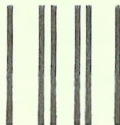

First-Class Mail  
Postage & Fees Paid  
USPS  
Permit No. G-10

- Sender: Please print your name, address, and ZIP+4<sup>®</sup> in this box<sup>•</sup>

**UNITED STATES  
DEPARTMENT OF THE INTERIOR  
Bureau of Land Management  
Arizona State Office  
One N. Central Avenue, Suite 800  
Phoenix, AZ 85004-4427**





# United States Department of the Interior



BUREAU OF LAND MANAGEMENT

Arizona State Office

One North Central Avenue, Suite 800

Phoenix, Arizona 85004-4427

[www.blm.gov/az/](http://www.blm.gov/az/)

**JUL 21 2015**

In Reply Refer To:

3800 (9310) RM

**AMC430837**

CERTIFIED MAIL – RETURN RECEIPT REQUESTED NO. 7014 0150 0000 5453 1105

## NOTICE

VIRGIL L BAKER

6790 S OAKMONT DR

CHANDLER, AZ 85249-8679

:  
:  
:

This Notice Affects the Claims  
Shown in the Block Below.

---

AMC430837

GOLDDIGGERS 6

---

### Locator Requirements for Association Placer Mining Claims Additional Information Required

The Bureau of Land Management (BLM) Arizona State Office received the location notice(s) for the association placer mining claim(s) listed above. You are included as a locator of the claim(s).

You must be qualified to locate an association placer mining claim and your mining claim must conform to the requirements of Federal law, 30 U.S.C. 35, 36, and regulations at 43 CFR 3832.22. These laws allow the location of placer mining claims greater than 20 acres so long as each of the locators has a bona fide interest in the claims, and has located the claims independently, for their own self-interest, and in good faith. The law is well established that a person cannot use the names of his friends, relatives, employees or club members as locators in order to locate for his own benefit a greater area of placer ground than is allowable by law. A company or corporation is considered to be one entity, entitled to locate claims of no more than 20 acres in size. Any claim located using dummy locators is not a valid mining claim.

By recording these location notices with the BLM you are representing to the United States government that you meet the qualifications for locating an association placer claim and that you are not using the names of other persons as dummy locators to locate more than 20 acres per claim for your own benefit. In accordance with 43 CFR 3830.9, if you file a document that you know contains false, erroneous, or fictitious information or statements, you may be subject to criminal penalties under 18 U.S.C. 1001 and 43 U.S.C. 1212. The maximum penalty is 5 years in prison and/or a fine of \$250,000.

In accordance with 43 CFR 1822.10, all documents required to be filed with the BLM must contain the applicant's (claimant's) legal name and current address. Additionally, 43 CFR 3833.11 (b)(2) requires that a certificate of location of a mining claim or site contain the names and current mailing addresses of the locators of the claim.



In accordance with 43 CFR 3830.3, an agent may locate mining claims on your behalf as long as they are duly constituted and appointed.

Before we can complete the recordation of your association placer mining claims, we will need the following information:

1. A signed and notarized statement from each claimant that says: "I (enter claimant's name) authorized and am aware that I am listed as a locator on the location notice for AMC (enter claim numbers). I have a bona fide interest in these claims and I located the claims independently, for my own self-interest and in good faith. I certify that these claims are in no way being located for the benefit of a company, corporation, or another individual in order to gain additional acreage they are not entitled to in accordance with the law."
2. A legal document from each claimant (such as a notarized power of attorney) showing that the person signing the location notice is acting on their behalf as their duly constituted and appointed agent or authorized representative. The Power of Attorney cannot be over 3 years old, meaning it must have been executed within the last 3 years.

The claimants of the above named mining claim(s) are hereby afforded 30 days from receipt of this Notice in which to furnish the requested information. Failure to do so will subject the recordation of these claims to further adjudication which may result in a partial rejection of the recordation and a reduction in acreage claimed.

If, after reviewing the information in this letter you determine that you do not, in fact, qualify to locate an association placer mining claim, please relinquish the association placer mining claims and relocate as an individual placer mining claim under 43 CFR 3832.22(b).

In accordance with 43 CFR 3833.33, you may transfer, sell, or otherwise convey an association placer mining claim at any time to an equal or greater number of mining claimants. If you want to transfer an association placer claim to an individual or an association that is smaller in number than the association that located the claim, a) you must have discovered a valuable mineral deposit before the transfer (documentation will be requested); or b) upon notice from the BLM, you must reduce the acreage of the claim, if necessary, so that you meet the 20-acre per locator limit. Per 43 CFR 3830.5, a discovery means that you have found a valuable mineral deposit. Any association placer claim transferred that does not meet these requirements is not a valid mining claim.

If you have any questions please contact RéAnn Myers at 602-417-9413.

Sincerely,

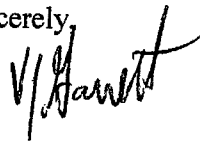

for

Rebecca Heick  
Acting Deputy State Director  
Division of Lands and Minerals

U.S. Postal Service™  
CERTIFIED MAIL™ RECEIPT

(Domestic Mail Only; No Insurance Coverage Provided)

For delivery information visit our website at [www.usps.com](http://www.usps.com)®

OFFICIAL USE

RECEIVED  
BLM AZ STATE OFFICE

Postage \$  
Certified Fee  
Return Receipt Fee  
(Endorsement Required)  
Restricted Delivery Fee  
(Endorsement Required)  
Total Postage & Fees \$

2015 JUL 21 P 4:23

Postmark  
Here

PHOENIX, ARIZONA

RICHARD JOHNSON  
11250 E STATE ROUTE 69 LOT 2126  
DEWEY, AZ 86327-4422  
9310/RM/AMC430837

Sent To

Street, Apt. No.,  
or PO Box No.

City, State, ZIP+

7014 0150 0000 5455 1365  
59ET 5345 0000 0510 4102

## Certified Mail Provides:

- A mailing receipt
- A unique identifier for your mailpiece
- A record of delivery kept by the Postal Service for two years

### *Important Reminders:*

- Certified Mail may ONLY be combined with First-Class Mail® or Priority Mail®.
- Certified Mail is *not* available for any class of international mail.
- NO INSURANCE COVERAGE IS PROVIDED with Certified Mail. For valuables, please consider Insured or Registered Mail.
- For an additional fee, a *Return Receipt* may be requested to provide proof of delivery. To obtain Return Receipt service, please complete and attach a Return Receipt (PS Form 3811) to the article and add applicable postage to cover the fee. Endorse mailpiece "Return Receipt Requested". To receive a fee waiver for a duplicate return receipt, a USPS® postmark on your Certified Mail receipt is required.
- For an additional fee, delivery may be restricted to the addressee or addressee's authorized agent. Advise the clerk or mark the mailpiece with the endorsement "*Restricted Delivery*".
- If a postmark on the Certified Mail receipt is desired, please present the article at the post office for postmarking. If a postmark on the Certified Mail receipt is not needed, detach and affix label with postage and mail.

**IMPORTANT: Save this receipt and present it when making an inquiry.**

PS Form 3800, August 2006 (Reverse) PSN 7530-02-000-9047

**SENDER: COMPLETE THIS SECTION**

- Complete items 1, 2, and 3. Also complete item 4 if Restricted Delivery is desired.
- Print your name and address on the reverse so that we can return the card to you.
- Attach this card to the back of the mailpiece, or on the front if space permits.

1. Article Addressed to:

**RICHARD JOHNSON**  
 11250 E STATE ROUTE 69 LOT 2126  
 DEWEY, AZ 86327-4422  
 9310/RM/AMC430837

2. Article Number

(Transfer from service label)

7014 0150 0000 5453 1365

PS Form 3811, July 2013

Domestic Return Receipt

**COMPLETE THIS SECTION ON DELIVERY**

A. Signature

X

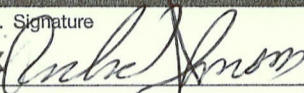
 Agent Addressee

B. Received by (Printed Name)



C. Date of Delivery

7/27/15

D. Is delivery address different from item 1?  Yes NoIf YES, enter delivery address below:  No

2015 JUL 30 P 2:47

PHOENIX, ARIZONA

3. Service Type

 Certified Mail® Priority Mail Express™ Registered Return Receipt for Merchandise Insured Mail Collect on Delivery

4. Restricted Delivery? (Extra Fee)

 Yes



UNITED STATES POSTAL SERVICE

AZ 852

27 JUL '15

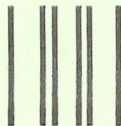

First-Class Mail  
Postage & Fees Paid  
USPS  
Permit No. G-10

PM 9 L

- Sender: Please print your name, address, and ZIP+4® in this box•

**UNITED STATES  
DEPARTMENT OF THE INTERIOR  
Bureau of Land Management  
Arizona State Office  
One N. Central Avenue, Suite 800  
Phoenix, AZ 85004-4427**





# United States Department of the Interior

BUREAU OF LAND MANAGEMENT

Arizona State Office

One North Central Avenue, Suite 800

Phoenix, Arizona 85004-4427

www.blm.gov/az/



**JUL 21 2015**

In Reply Refer To:

3800 (9310) RM

**AMC430837**

CERTIFIED MAIL – RETURN RECEIPT REQUESTED NO. 7014 0150 0000 5453 1365

## NOTICE

RICHARD JOHNSON

11250 E STATE ROUTE 69 LOT 2126

DEWEY, AZ 86327-4422

:  
:  
:

This Notice Affects the Claims

Shown in the Block Below.

---

AMC430837

GOLDDIGGERS 6

---

### Locator Requirements for Association Placer Mining Claims Additional Information Required

The Bureau of Land Management (BLM) Arizona State Office received the location notice(s) for the association placer mining claim(s) listed above. You are included as a locator of the claim(s).

You must be qualified to locate an association placer mining claim and your mining claim must conform to the requirements of Federal law, 30 U.S.C. 35, 36, and regulations at 43 CFR 3832.22. These laws allow the location of placer mining claims greater than 20 acres so long as each of the locators has a bona fide interest in the claims, and has located the claims independently, for their own self-interest, and in good faith. The law is well established that a person cannot use the names of his friends, relatives, employees or club members as locators in order to locate for his own benefit a greater area of placer ground than is allowable by law. A company or corporation is considered to be one entity, entitled to locate claims of no more than 20 acres in size. Any claim located using dummy locators is not a valid mining claim.

By recording these location notices with the BLM you are representing to the United States government that you meet the qualifications for locating an association placer claim and that you are not using the names of other persons as dummy locators to locate more than 20 acres per claim for your own benefit. In accordance with 43 CFR 3830.9, if you file a document that you know contains false, erroneous, or fictitious information or statements, you may be subject to criminal penalties under 18 U.S.C. 1001 and 43 U.S.C. 1212. The maximum penalty is 5 years in prison and/or a fine of \$250,000.

In accordance with 43 CFR 1822.10, all documents required to be filed with the BLM must contain the applicant's (claimant's) legal name and current address. Additionally, 43 CFR 3833.11 (b)(2) requires that a certificate of location of a mining claim or site contain the names and current mailing addresses of the locators of the claim.

RECEIVED POA ONLY 8/17/2015.  
80 ACRE CLAIM HAS ENOUGH LOCATORS  
WHO PROVIDED STATEMENTS TO HOLD 80 ACRES. R.M.

In accordance with 43 CFR 3830.3, an agent may locate mining claims on your behalf as long as they are duly constituted and appointed.

Before we can complete the recordation of your association placer mining claims, we will need the following information:

1. A signed and notarized statement from each claimant that says: "I (enter claimant's name) authorized and am aware that I am listed as a locator on the location notice for AMC (enter claim numbers). I have a bona fide interest in these claims and I located the claims independently, for my own self-interest and in good faith. I certify that these claims are in no way being located for the benefit of a company, corporation, or another individual in order to gain additional acreage they are not entitled to in accordance with the law."
2. A legal document from each claimant (such as a notarized power of attorney) showing that the person signing the location notice is acting on their behalf as their duly constituted and appointed agent or authorized representative. The Power of Attorney cannot be over 3 years old, meaning it must have been executed within the last 3 years.

The claimants of the above named mining claim(s) are hereby afforded 30 days from receipt of this Notice in which to furnish the requested information. Failure to do so will subject the recordation of these claims to further adjudication which may result in a partial rejection of the recordation and a reduction in acreage claimed.

If, after reviewing the information in this letter you determine that you do not, in fact, qualify to locate an association placer mining claim, please relinquish the association placer mining claims and relocate as an individual placer mining claim under 43 CFR 3832.22(b).

In accordance with 43 CFR 3833.33, you may transfer, sell, or otherwise convey an association placer mining claim at any time to an equal or greater number of mining claimants. If you want to transfer an association placer claim to an individual or an association that is smaller in number than the association that located the claim, a) you must have discovered a valuable mineral deposit before the transfer (documentation will be requested); or b) upon notice from the BLM, you must reduce the acreage of the claim, if necessary, so that you meet the 20-acre per locator limit. Per 43 CFR 3830.5, a discovery means that you have found a valuable mineral deposit. Any association placer claim transferred that does not meet these requirements is not a valid mining claim.

If you have any questions please contact RéAnn Myers at 602-417-9413.

Sincerely,



for

Rebecca Heick  
Acting Deputy State Director  
Division of Lands and Minerals



**NOTICE!!**

**These documents have been scanned!**

**Do not place un-scanned documents beneath this notice!**

**Do not remove this notice from this file!**

GPO Jacket No. 560-102  
Print Order 61540  
Rise Business Services, LLC  
Job=AZ15 5/9/2019



Box Number= AZ15028



Claim Begin-End: AMC430837-AMC430837

3 Transfers



AZ15028-11

AMC430583-AMC430889



**NO  
DOCUMENTS  
FOUND**

NO DOCUMENTS FOUND  
NO DOCUMENTS FOUND

**NOTICE!!**

**These documents have been scanned!**

**Do not place un-scanned documents beneath this notice!**

**Do not remove this notice from this file!**

GPO Jacket No. 560-102  
Print Order 61540  
Rise Business Services, LLC  
Job=AZ15 5/9/2019



Box Number= AZ15028



Claim Begin-End: AMC430837-AMC430837

4 Annual Filings



AZ15028-11

AMC430583-AMC430889



*Sent  
8/10/20*

UNITED STATES  
DEPARTMENT OF THE INTERIOR  
BUREAU OF LAND MANAGEMENT  
**MAINTENANCE FEE PAYMENT FORM  
FOR PLACER MINING CLAIMS**

Remitter Name: Patti K Wooldridge Agent of Record

Mailing Address: 1020 E Saddle Butte St

City, State, Zip: Apache Junction, AZ., 85119

Check here if this is a change of address.

**FOR COUNTY RECORDER'S USE**

No. of claims 01  
Total due BLM \$ 660.00

1. The maintenance fee may be paid by cash, check, money order, Bureau of Land Management (BLM) Declining Deposit Account, or credit card (VISA, American Express, Discover, or MasterCard). Payments must be remitted to the BLM State Office where your claim or site is recorded and received on or before September 1. If the payment is mailed, the envelope must be postmarked by a bona fide delivery service on or before September 1 and received at the proper BLM State Office within 15 calendar days after the due date. Payments may also be made by telephone using a credit card. A complete listing of BLM State Offices with their addresses and phone numbers can be found at <http://www.blm.gov>.

2. The maintenance fee for the following claim(s) applies to the assessment year 2021

CLAIM NAME	BLM SERIAL NO.	ACRES IN CLAIM	PAYMENT DUE TO THE BLM (See Instructions on Page 2)
Golddiggers 6	AMC430837	80	\$ 0
			\$ 0
			\$ 0
			\$ 0
			\$ 0
			\$ 0
			\$ 0
			\$ 0
			\$ 0
			\$ 0

RECEIVED  
2020 AUG 12 A 8:12  
PHOENIX, ARIZONA

Use a separate sheet for additional claim names, serial numbers, and claimant names and addresses

**ENTERED**  
AUG 17 2020  
By: *[Signature]*

# 478.1116



**United States Department of the Interior**  
**Bureau of Land Management**  
 DIV OF LANDS, MINRLS & ENERGY  
 ONE N CENTRAL AVE  
 PHOENIX, AZ 85004 -4427  
 Phone: 602-417-9200

Receipt

No: 4781116

<b>Transaction #:</b> 4908123	
<b>Date of Transaction:</b> 08/14/2020	
<b>CUSTOMER:</b>	
PATTI WOOLDRIDGE 1020 E SADDLE BUTTE ST APACHE JUNCTION, AZ 85119-9875 US	

LINE #	QTY	DESCRIPTION	REMARKS	UNIT PRICE	TOTAL
1	1.00	LOCATABLE MINERALS / MINING CLAIMS-NOT NEW-UNADJUD, ONE AUTH NO. ONLY / MINING CLAIM MONEY RECEIVED CASES: AMC430837/\$660.00	MAINT	- n/a -	660.00
<b>TOTAL:</b>					<b>\$660.00</b>

PAYMENT INFORMATION			
1	AMOUNT:	660.00	POSTMARKED: N/A
	TYPE:	CHECK	RECEIVED: 08/12/2020
	CHECK NO:	1565	
	NAME:	WOOLDRIDGE, PATTI 1020 E SADDLE BUTTE ST APACHE JUNCTION AZ 85119-9875 US	

<b>REMARKS</b>

This receipt was generated by the automated BLM Collections and Billing System and is a paper representation of a portion of the official electronic record contained therein.





RECEIVED  
BLMAZ STATE OFFICE

17 2020 AUG 12 A 8:12

PHOENIX, ARIZONA

PHOENIX, AZ 852

10 AUG 2020 PM 10:1



Bureau of Land Management  
One N. Central Ave #800  
Phoenix, AZ, 85004

85004-442700



Amc 430837

UNITED STATES  
DEPARTMENT OF THE INTERIOR  
BUREAU OF LAND MANAGEMENT  
**MAINTENANCE FEE PAYMENT FORM  
FOR PLACER MINING CLAIMS**

Remitter Name: PATTI K WOULD RIDGE <sup>- AGENT</sup>  
Mailing Address: 1020 E. SADDLE BUTTE ST  
City, State, Zip: APACHE JUNCTION AZ 85119

Check here if this is a change of address.

**FOR COUNTY RECORDER'S USE**

No. of claims 1  
Total due BLM \$ 660<sup>00</sup>

- The maintenance fee may be paid by cash, check, money order, Bureau of Land Management (BLM) Declining Deposit Account, or credit card (VISA, American Express, Discover, or MasterCard). Payments must be remitted to the BLM State Office where your claim or site is recorded and received on or before September 1. If the payment is mailed, the envelope must be postmarked by a bona fide delivery service on or before September 1 and received at the proper BLM State Office within 15 calendar days after the due date. Payments may also be made by telephone using a credit card. A complete listing of BLM State Offices with their addresses and phone numbers can be found at <http://www.blm.gov>.
- The maintenance fee for the following claim(s) applies to the assessment year 2020

CLAIM NAME	BLM SERIAL NO.	ACRES IN CLAIM	PAYMENT DUE TO THE BLM (See Instructions on Page 2)
GOLD DIGGERS 6	AMC 430837	80	\$660. <sup>00</sup>

RECEIVED  
STATE OFFICE  
PHOENIX, ARIZONA  
2019 AUG -5 P 12:45

Use a separate sheet for additional claim names, serial numbers, and claimant names and addresses. /

NO. OF CLAIMS  
AMOUNT 660<sup>00</sup>  
RECEIPT NO. 4524026  
INIT. PER  
\*\*BLM-ASO\*\*

(Continued on page 2)  
**ENTERED**  
AUG 06 2019  
BY: [Signature]

**United States Department of the Interior**  
**Bureau of Land Management**  
 DIV OF LANDS, MINRLS & ENERGY  
 ONE N CENTRAL AVE  
 PHOENIX, AZ 85004 -4427  
 Phone: 602-417-9200

Receipt	
No:	4524026

**Transaction #:** 4644731  
**Date of Transaction:** 08/05/2019

CUSTOMER:	
PATTI WOOLDRIDGE	1020 E SADDLE BUTTE ST
APACHE JUNCTION, AZ 85119-9875 US	

LINE #	QTY	DESCRIPTION	REMARKS	UNIT PRICE	TOTAL
1	1.00	LOCATABLE MINERALS / MINING CLAIMS-NOT NEW-UNADJUD, ONE AUTH NO. ONLY / MINING CLAIM MONEY RECEIVED CASES: AMC430837/\$660.00	2020 MAINT/1 EIGHTY ACRES	- n/a -	660.00
<b>TOTAL:</b>					<b>\$660.00</b>

PAYMENT INFORMATION			
1	AMOUNT:	660.00	POSTMARKED: N/A
	TYPE:	CHECK	RECEIVED: 08/05/2019
	CHECK NO:	1554	
	NAME:	WOOLDRIDGE, PATTI 1020 E SADDLE BUTTE ST APACHE JUNCTION AZ 85119-9875 US	

REMARKS
602-570-1493

This receipt was generated by the automated BLM Collections and Billing System and is a paper representation of a portion of the official electronic record contained therein.

UNITED STATES  
DEPARTMENT OF THE INTERIOR  
BUREAU OF LAND MANAGEMENT  
**MAINTENANCE FEE PAYMENT FORM  
FOR PLACER MINING CLAIMS**

430837

Remitter Name: PATTI K WOULDRIE <sup>- AGENT</sup>

Mailing Address: 1020 E. SADDLE BUTTE ST

City, State, Zip: APACHE JUNCTION, AZ 85119

Check here if this is a change of address.

**FOR COUNTY RECORDER'S USE**

No. of claims 1  
Total due BLM \$ 620.00

- The maintenance fee may be paid by cash, check, money order, Bureau of Land Management (BLM) Declining Deposit Account, or credit card (VISA, American Express, Discover, or MasterCard). Payments must be remitted to the BLM State Office where your claim or site is recorded and received on or before September 1. If the payment is mailed, the envelope must be postmarked by a bona fide delivery service on or before September 1 and received at the proper BLM State Office within 15 calendar days after the due date. Payments may also be made by telephone using a credit card. A complete listing of BLM State Offices with their addresses and phone numbers can be found at <http://www.blm.gov>.
- The maintenance fee for the following claim(s) applies to the assessment year \_\_\_\_\_.

CLAIM NAME	BLM SERIAL NO.	ACRES IN CLAIM	PAYMENT DUE TO THE BLM (See Instructions on Page 2)
GOLDDIGGERS 6	AMC 430837	80	\$620. <sup>00</sup>

RECEIVED  
 BLM STATE OFFICE  
 2018 AUG 13 P 2:12  
 PHOENIX, ARIZONA

Use a separate sheet for additional claim names, serial numbers, and claimant names and addresses.

(Continued on page 2)

#4335833

**INTEREST**  
 AUG 21 2018  
 BY: RAM





Ms Patti K Wooldridge  
1020 E Saddle Butte St  
Apache Jct, AZ 85119

**CERTIFIED MAIL®**



7015 0640 0000 3965 6653



1000

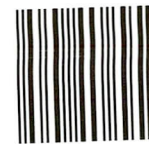

85004

U.S. POSTAGE  
PAID  
APACHE JUNCTION, AZ  
85120  
AUG 10, 18  
AMOUNT

**\$6.70**

R2304M111460-19

RECEIVED  
BLM AZ STATE OFFICE

**RETURN RECEIPT  
REQUESTED**

2018 AUG 13 P 2:12

PHOENIX, ARIZONA

Bureau of Land Management  
One N. Central Ave.  
Phoenix, AZ, 85004-4427

**RETURN RECEIPT  
REQUESTED**

85004\$4414 C041



PLACE STICKER AT TOP OF ENVELOPE TO THE RIGHT  
OF THE RETURN ADDRESS. FOLD AT DOTTED LINE



**United States Department of the Interior**  
**Bureau of Land Management**  
 DIV OF LANDS, MINRLS & ENERGY  
 ONE N CENTRAL AVE  
 PHOENIX, AZ 85004 -4427  
 Phone: 602-417-9200

Receipt

No: 4235833

<b>Transaction #:</b> 4351198	
<b>Date of Transaction:</b> 08/15/2018	
CUSTOMER:	
PATTI WOOLDRIDGE 1020 E SADDLE BUTTE ST APACHE JUNCTION, AZ 85119-9875 US	

LINE #	QTY	DESCRIPTION	REMARKS	UNIT PRICE	TOTAL
1	1.00	LOCATABLE MINERALS / MINING CLAIMS- NOT NEW-UNADJUD, ONE AUTH NO. ONLY / MINING CLAIM MONEY RECEIVED <b>CASES: AMC430837/\$620.00</b>	MAINT 2019/1	- n/a -	620.00
<b>TOTAL:</b>					<b>\$620.00</b>

PAYMENT INFORMATION			
1	AMOUNT:	620.00	POSTMARKED: N/A
	TYPE:	CHECK	RECEIVED: 08/13/2018
	CHECK NO:	1526	
	NAME:	WOOLDRIDGE, PATTI 1020 E SADDLE BUTTE ST APACHE JUNCTION AZ 85119-9875 US	

REMARKS

This receipt was generated by the automated BLM Collections and Billing System and is a paper representation of a portion of the official electronic record contained therein.

UNITED STATES  
DEPARTMENT OF THE INTERIOR  
BUREAU OF LAND MANAGEMENT  
**MAINTENANCE FEE PAYMENT FORM  
FOR PLACER MINING CLAIMS**

430837

Remitter Name: PATTI K WOOLDRIDGE <sup>AGENT</sup>  
 Mailing Address: 1020 E. SADDLE BUTTE ST  
 City, State, Zip: APACHE JUNCTION AZ 85119

Check here if this is a change of address.

**FOR COUNTY RECORDER'S USE**

No. of claims 1  
 Total due BLM \$ \_\_\_\_\_

- The maintenance fee may be paid by cash, check, money order, Bureau of Land Management (BLM) Declining Deposit Account, or credit card (VISA, American Express, Discover, or MasterCard). Payments must be remitted to the BLM State Office where your claim or site is recorded and received on or before September 1. If the payment is mailed, the envelope must be postmarked by a bona fide delivery service on or before September 1 and received at the proper BLM State Office within 15 calendar days after the due date. Payments may also be made by telephone using a credit card. A complete listing of BLM State Offices with their addresses and phone numbers can be found at <http://www.blm.gov>.
- The maintenance fee for the following claim(s) applies to the assessment year 17/18.

CLAIM NAME	BLM SERIAL NO.	ACRES IN CLAIM	PAYMENT DUE TO THE BLM (See Instructions on Page 2)
GOLD DIGGERS 6	AMC 430837	80	\$620. <sup>00</sup>

RECEIVED  
BLM STATE OFFICE  
2017 AUG 24 A 11:09  
PHOENIX, ARIZONA

Use a separate sheet for additional claim names, serial numbers, and claimant names and addresses.

# 3954912

(Continued on page 2)

ENTERED  
AUG 25 2017  
BY: RAM

**United States Department of the Interior**  
**Bureau of Land Management**  
 DIV OF LANDS, MINRLS & ENERGY  
 ONE N CENTRAL AVE  
 PHOENIX, AZ 85004 -4427  
 Phone: 602-417-9200

Receipt

No: 3954912

<b>Transaction #:</b> 4064670	
<b>Date of Transaction:</b> 08/24/2017	
CUSTOMER:	
PATTI WOOLDRIDGE 1020 E SADDLE BUTTE ST APACHE JUNCTION, AZ 85119-9875 US	

LINE #	QTY	DESCRIPTION	REMARKS	UNIT PRICE	TOTAL
1	1.00	LOCATABLE MINERALS / MINING CLAIMS- NOT NEW-UNADJUD, ONE AUTH NO. ONLY / MINING CLAIM MONEY RECEIVED CASES: AMC430837/\$620.00	MAINT 2018/1	- n/a -	620.00
<b>TOTAL:</b>					<b>\$620.00</b>

PAYMENT INFORMATION			
1	AMOUNT:	620.00	POSTMARKED: N/A
	TYPE:	CHECK	RECEIVED: 08/24/2017
	CHECK NO:	1473	
	NAME:	WOOLDRIDGE, PATTI 1020 E SADDLE BUTTE ST APACHE JUNCTION AZ 85119-9875 US	

REMARKS

This receipt was generated by the automated BLM Collections and Billing System and is a paper representation of a portion of the official electronic record contained therein.



UNITED STATES  
DEPARTMENT OF THE INTERIOR  
BUREAU OF LAND MANAGEMENT  
**MAINTENANCE FEE PAYMENT FORM  
FOR PLACER MINING CLAIMS**

430837

Remitter Name: PATTI K WOULD RIDGE <sup>AGENT</sup>  
Mailing Address: 1020 G. SADDLE BUTTE ST  
City, State, Zip: APACHE JUNCTION, AZ 85119

Check here if this is a change of address.

**FOR COUNTY RECORDER'S USE**

No. of claims 1  
Total due BLM \$ 620.<sup>00</sup>

- The maintenance fee may be paid by cash, check, money order, Bureau of Land Management (BLM) Declining Deposit Account, or credit card (VISA, American Express, Discover, or MasterCard). Payments must be remitted to the BLM State Office where your claim or site is recorded and received on or before September 1. If the payment is mailed, the envelope must be postmarked by a bona fide delivery service on or before September 1 and received at the proper BLM State Office within 15 calendar days after the due date. Payments may also be made by telephone using a credit card. A complete listing of BLM State Offices with their addresses and phone numbers can be found at <http://www.blm.gov>.
- The maintenance fee for the following claim(s) applies to the assessment year \_\_\_\_\_.

CLAIM NAME	BLM SERIAL NO.	ACRES IN CLAIM	PAYMENT DUE TO THE BLM (See Instructions on Page 2)
GOLD DIGGERS 6	AMC 430837	80	\$620. <sup>00</sup>

RECEIVED  
BLM AZ STATE OFFICE  
2016 AUG 25 A 11:23  
PHOENIX, ARIZONA

Use a separate sheet for additional claim names, serial numbers, and claimant names and addresses.

(Continued on page 2)

INTEREST  
AUG 26 2016  
BY: RAM

PER Receipt # 3040873

**DEPARTMENT OF THE INTERIOR  
BUREAU OF LAND MANAGEMENT  
MINING CLAIMS  
(MASS) Serial Register Page**

Run Date/Time: 08/25/16 12:20 PM

Page 1 of 1

**01 10-21-1976;090STAT0090;43USC1744**

**Total Acres**

**Serial Number**

**Case Type 384201: PLACER CLAIM**

**80.000**

**AMC430837**

**Claim Name: GOLDDIGGERS 6**

**Lead File Number**

**Case Disposition: ACTIVE**

**AMC430837**

**Required Maintenance Fee: \$620.00**

**Name & Address**

**Int Rel**

ALMOS JERRY 29 RIVER RD CASCADE, MT 59421-8101	CLAIMANT
BAKER VIRGIL L 6790 S OAKMONT DR CHANDLER, AZ 85249-8679	CLAIMANT
JOHNSON RICHARD 11250 E STATE ROUTE 69, LOT 2126 DEWEY, AZ 86327-4422	CLAIMANT
KIVELA LARRY 4245 E LIBERTY LN PHOENIX, AZ 85048-0537	CLAIMANT
MONTPAS ROBERT 146 N MERRILL RD LOT 106 APACHE JUNCTION, AZ 85120-3244	CLAIMANT
WOOLDRIDGE PATTI 1020 E SADDLE BUTTE ST APACHE JUNCTION, AZ 85119-9875	CLAIMANT

**County / State**

**District**

GILA County, AZ

GILA DO

**Mer Twp Rng Sec**

**Subdivision**

14 0090N 0100E 005

NW

<b>Act Date</b>	<b>Code</b>	<b>Action Text</b>	<b>Action Remarks</b>	<b>Receipt Number</b>
04/06/2015	403	LOCATION DATE		
04/06/2015	395	RECORDATION NOTICE RECD	1	3267210
08/17/2015	782	MAINTENANCE FEE PAYMENT	2016;\$620	3368545
04/06/2015	484	LOCATION YEAR / MAINTENAN	2015;\$155	3267210
07/21/2015	393	DECISION/NOTICE ISSUED	ASSOC PLACER INFO REQ	
06/29/2015	669	LAND STATUS CHECKED		
04/06/2015	501	ACCT ADV IN LEAD FILE	AMC430837;	
04/06/2015	685	ADDL MAINTENANCE FEE	2015;\$465	3267210

**Line Nr**      **Remarks**



**United States Department of the Interior**  
**Bureau of Land Management**  
 DIV OF LANDS, MINRLS & ENERGY  
 ONE N CENTRAL AVE  
 PHOENIX, AZ 85004 -4427  
 Phone: 602-417-9200

Receipt

No: 3640873

<b>Transaction #:</b> 3744818	
<b>Date of Transaction:</b> 08/25/2016	
CUSTOMER:	
PATTI WOOLDRIDGE 1020 E SADDLE BUTTE ST APACHE JUNCTION, AZ 85119-9875 US	

LINE #	QTY	DESCRIPTION	REMARKS	UNIT PRICE	TOTAL
1	1.00	LOCATABLE MINERALS / MINING CLAIMS- NOT NEW-UNADJUD, ONE AUTH NO. ONLY / MINING CLAIM MONEY RECEIVED CASES: AMC430837/\$620.00	2017 MAINT/1	- n/a -	620.00
<b>TOTAL:</b>					<b>\$620.00</b>

PAYMENT INFORMATION			
1	AMOUNT:	620.00	POSTMARKED: N/A
	TYPE:	CHECK	RECEIVED: 08/25/2016
	CHECK NO:	1409	
	NAME:	WOOLDRIDGE, PATTI 1020 E SADDLE BUTTE ST APACHE JUNCTION AZ 85119-9875 US	

REMARKS

This receipt was generated by the automated BLM Collections and Billing System and is a paper representation of a portion of the official electronic record contained therein.

430837

**MAINTENANCE FEE PAYMENT 2016**

AGENT-POA

Claimant Name: PATTI WOOLDRIDGE

Address: 1020 E. SADDLE BUTTE ST.

City: JUNCTION State: AZ Zip: 85119

Telephone: TRADERSPLUS@MSN.COM

E-mail address: 480-288-6085(A)602-570-1493

Signature: *Patti Wooldrige*

Check here if this is a change of address.

RECEIVED  
BLM AZ STATE OFFICE  
2015 AUG 17 A 11:37  
PHOENIX, ARIZONA

BLM  
Date  
Stamp

LINE NO.	AMC NUMBER	CLAIM/SITE NAME	COUNTY RECORDER DATA (If available)	TWP	RNG	SEC
1	430837	GOLDDIGGERS6		9N	10E	5
2						
3						
4						
5						
6						
7						
8						
9						
10						

List additional claims on Form MCF114.

Bureau of Land Management  
Arizona State Office  
[www.blm.gov/az/](http://www.blm.gov/az/)

No. of Claims\*: 1 x \$155 = 620.00  
 Check No: 1341 Init. ERG  
 Receipt No.: 3368545  
 For BLM Use Only 80 ACRES

\* \$155 per lode mining claim, mill site, or tunnel site; and \$155 for each 20 acres or portion thereof for each placer mining claim.

Form: MCF112  
Revised July 2014

This form is available from the Arizona Geological Survey and may be reproduced.

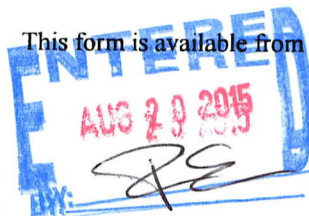



**United States Department of the Interior**  
**Bureau of Land Management**  
 LANDS/RECREATION & PLANNING  
 ONE N CENTRAL AVE  
 PHOENIX, AZ 85004 -2203  
 Phone: 602-417-9200

Receipt

No: 3368545

<b>Transaction #:</b> 3466641	
<b>Date of Transaction:</b> 08/17/2015	
<b>CUSTOMER:</b>	
PATTI WOOLDRIDGE 1020 E SADDLE BUTTE ST APACHE JUNCTION, AZ 85119-9875 US	

LINE #	QTY	DESCRIPTION	REMARKS	UNIT PRICE	TOTAL
1	1.00	LOCATABLE MINERALS / MINING CLAIMS- NOT NEW-UNADJUD, ONE AUTH NO. ONLY / MINING CLAIM MONEY RECEIVED <b>CASES: AMC430837/\$620.00</b>	2016 MAINT (1)	- n/a -	620.00
<b>TOTAL:</b>					<b>\$620.00</b>

PAYMENT INFORMATION			
1	AMOUNT:	620.00	POSTMARKED: N/A
	TYPE:	CHECK	RECEIVED: 08/17/2015
	CHECK NO:	1341	
	NAME:	WOOLDRIDGE, PATTI 1020 E SADDLE BUTTE ST APACHE JUNCTION AZ 85119-9875 US	

REMARKS

This receipt was generated by the automated BLM Collections and Billing System and is a paper representation of a portion of the official electronic record contained therein.



**NOTICE!!**

**These documents have been scanned!**

**Do not place un-scanned documents beneath this notice!**

**Do not remove this notice from this file!**

GPO Jacket No. 560-102  
Print Order 61540  
Rise Business Services, LLC  
Job=AZ15 5/9/2019



Box Number= AZ15028



Claim Begin-End: AMC430837-AMC430837

5 Miscellaneous



AZ15028-11

AMC430583-AMC430889

7-26-2015

"I Patti Wooldridge authorized and am aware that I am listed as a locator on the location notice for (AMC 430837). I have a bona fide interest in these claims and I located the claims independently, for my own self-interest and in good faith. I certify that these claims are in no way being located for the benefit of a company, corporation, or another individual in order to gain additional acreage they are not entitled to in accordance with the law."

Patti Wooldridge 8/13/15

Patti Wooldridge, As Principal

Address: 1020 E. Saddle Butte St. Apache Junction, AZ., 85119

STATE OF Arizona

COUNTY OF Pinal

Patti Wooldridge personally appeared before me and acknowledged the execution of the document for the purposes set forth herein.

Dated: AUGUST 13, 2015

\* SEE ATTACHED ACKNOWLEDGMENT DOCUMENT

Notary Public

PHOENIX, ARIZONA  
2015 AUG 17 A 11:20  
RECEIVED  
PLM AZ STATE OFFICE

**INDIVIDUAL ACKNOWLEDGMENT**

State/Commonwealth of ARIZONA }  
County of PINAL } ss.

On this the 13 day of AUGUST, 2015, before me,  
Day Month Year

JESSICA ARCHER, the undersigned Notary Public,  
Name of Notary Public

personally appeared PATTI WOOLDRIDGE,  
Name(s) of Signer(s)

- personally known to me - OR -
- proved to me on the basis of satisfactory evidence

to be the person(s) whose name(s) is/are subscribed to the within instrument, and acknowledged to me that he/she/they executed the same for the purposes therein stated.

WITNESS my hand and official seal.

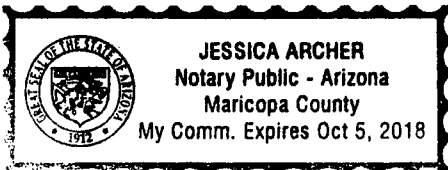

[Signature]  
Signature of Notary Public

EXP 10/5/18

Place Notary Seal/Stamp Above

Any Other Required Information  
(Printed Name of Notary, Expiration Date, etc.)

**OPTIONAL**

This section is required for notarizations performed in Arizona but is optional in other states. Completing this information can deter alteration of the document or fraudulent reattachment of this form to an unintended document.

**Description of Attached Document**

Title or Type of Document: LOCATION NOTICE (AMC 430837)

Document Date: 7-26-15 Number of Pages: 1 PAGE + 1 ACK

Signer(s) Other Than Named Above: \_\_\_\_\_

7-26-2015

**POWER OF ATTORNEY**

Bob Montpas the "Principal" of 146 N, Merrill Rd., #106, Apache Junction AZ., 85120-3244 (new address). (Formerly 4301 Atherton Rd., Burton MI., 48519). herewith appoints Patti K. Wooldridge of 1020 E. Saddle Butte St., Apache Junction, AZ., 85119 as their attorney in fact to act in the place and stead and with the same authority as "Principle" would have to do the following acts:

To act for me in the regard to the following: Mining Claim: GOLDDIGGERS 6 (AMC430837) Described as: East 1/2 of the NW 1/4 Section of Section 5-T9N., R-10E., Gila and Salt River Baseline and Meridian, Gila County AZ. Gila Salt River Base and Meridian, Arizona.

To represent me re: any and all matters pertaining to the conduct of any and all business with any lawful authority or private individual or business, regarding the noted mining claims in the document.

x Bob Montpas Date: 8-7-15

Bob Montpas, As Principle

STATE OF Arizona

COUNTY OF ~~Pinal~~ Yavapai

Bob Montpas personally appeared before me and acknowledged the execution of this Power of Attorney for the purposes set forth therein.

Dated: 8-7-15

Jordan Huff  
Notary Public



RECEIVED  
M AZ STATE OFFICE  
2015 AUG 17 A 11: 20  
PHOENIX, ARIZONA



7-26-2015

"I Bob Montpas authorized and am aware that I am listed as a locator on the location notice for (AMC 430837). I have a bona fide interest in these claims and I located the claims independently, for my own self-interest and in good faith. I certify that these claims are in no way being located for the benefit of a company, corporation, or another individual in order to gain additional acreage they are not entitled to in accordance with the law."

*Bob Montpas*

Bob Montpas, As Principal

Address: 146 N. Merrill Rd. #106., Apache Junction, AZ., 85120-3244

STATE OF Arizona

COUNTY OF Pinal *Yavapai*

Bob Montpas personally appeared before me and acknowledged the execution of the document for the purposes set forth herein.

Dated: *8-7-15*



*Jordan Huff*  
Notary Public

PHOENIX, ARIZONA  
2015 AUG 17 A 11: 20  
RECEIVED  
PLM AZ STATE OFFICE

7-26-2015

POWER OF ATTORNEY

Larry Kivela the "Principal" of 4345 E. Liberty Lane, Phoenix, AZ 85048. herewith appoints Patti K. Wooldridge of 1020 E. Saddle Butte St., Apache Junction, AZ., 85119 as their attorney in fact to act in the place and stead and with the same authority as "Principle" would have to do the following acts:

To act for me in the regard to the following: Mining Claim: GOLDDIGGERS 6 (AMC430837) Described as: East 1/2 of the NW 1/4 Section of Section 5-T9N., R- 10E., Gila and Salt River Baseline and Meridian, Gila County AZ. Gila Salt River Base and Meridian, Arizona.

To represent me re: any and all matters pertaining to the conduct of any and all business with any lawful authority or private individual or business, regarding the noted mining claims in the document.

X Larry Kivela Date: 7/30/15  
Larry Kivela, As Principle

STATE OF Arizona

COUNTY OF Pinal

Larry Kivela personally appeared before me and acknowledged the execution of this Power of Attorney for the purposes set forth therein.

Dated: 07/30/15

[Signature]  
Notary Public

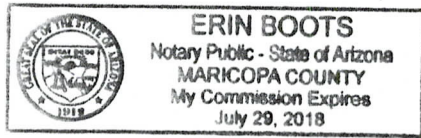

PHOENIX, ARIZONA

2015 AUG 17 A 11: 20

RECEIVED  
AZ STATE OFFICE

7-26-2015

"I Larry Kivela authorized and am aware that I am listed as a locator on the location notice for (AMC 430837). I have a bona fide interest in these claims and I located the claims independently, for my own self-interest and in good faith. I certify that these claims are in no way being located for the benefit of a company, corporation, or another individual in order to gain additional acreage they are not entitled to in accordance with the law."

*Larry Kivela*

*7/30/15*

Larry Kivela, As Principal

Address: 4245 E. Liberty Lane Phoenix AZ. 85048

STATE OF Arizona

COUNTY OF Maricopa

Larry Kivela personally appeared before me and acknowledged the execution of the document for the purposes set forth herein.

Dated: *07/30/15*

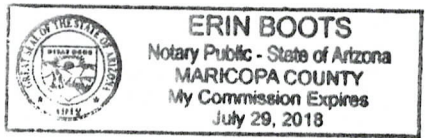

*Erin Boots*

Notary Public

RECEIVED  
PLM AZ STATE OFFICE  
2015 AUG 17 A 11: 20  
PHOENIX, ARIZONA

7-26-2015

**POWER OF ATTORNEY**

Jerry Almos the "Principal" of 29 River Rd., Cascade, Montana 59421 herewith appoints Patti K. Wooldridge of 1020 E. Saddle Butte St., Apache Junction, AZ., 85119 as their attorney in fact to act in the place and stead and with the same authority as "Principle" would have to do the following acts:

To act for me in the regard to the following: Mining Claim: GOLDDIGGERS 6 (AMC430837) Described as: East 1/2 of the NW 1/4 Section of Section 5-T9N., R-10E., Gila and Salt River Baseline and Meridian, Gila County AZ. Gila Salt River Base and Meridian, Arizona.

To represent me re: any and all matters pertaining to the conduct of any and all business with any lawful authority or private individual or business, regarding the noted mining claims in the document.

X Jerry Almos Date: 7-31-15

Jerry Almos, As Principle

STATE OF Arizona

COUNTY OF Pinal

Jerry Almos personally appeared before me and acknowledged the execution of this Power of Attorney for the purposes set forth therein.

Dated: 7-31-2015

Nancy C Lemire

Notary Public

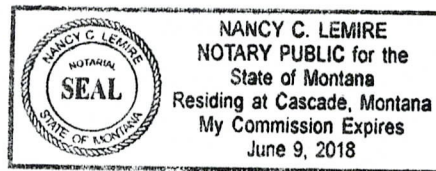

PHOENIX, ARIZONA  
2015 AUG 17 A 11:20  
RECEIVED  
MONTANA STATE OFFICE



7-26-2015

"I Jerry Almos authorized and am aware that I am listed as a locator on the location notice for (AMC 430837). I have a bona fide interest in these claims and I located the claims independently, for my own self-interest and in good faith. I certify that these claims are in no way being located for the benefit of a company, corporation, or another individual in order to gain additional acreage they are not entitled to in accordance with the law."

*Jerry Almos* 7/31/15

Jerry Almos, As Principal

Address: 29 River Rd., Cascade, MT., 59421

STATE OF Arizona

COUNTY OF Pinal

Jerry Almos personally appeared before me and acknowledged the execution of the document for the purposes set forth herein.

Dated: 7-31-2015

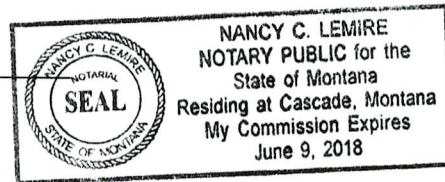

*Nancy C Lemire*

Notary Public

RECEIVED  
PLM AZ STATE OFFICE  
2015 AUG 17 A 11:20  
PHOENIX, ARIZONA

7-26-2015

POWER OF ATTORNEY

Virgil Baker the "Principal" of 85 forest svc rd633, Wheatland, Wy 82201(new address). (Formerly 6790 S.Oakmont Dr., Chandler, Az 85249). herewith appoints Patti K. Wooldridge of 1020 E. Saddle Butte St., Apache Junction, AZ., 85119 as their attorney in fact to act in the place and stead and with the same authority as "Principle" would have to do the following acts:

To act for me in the regard to the following: Mining Claim: GOLDDIGGERS 6 (AMC430837) Described as: East 1/2 of the NW 1/4 Section of Section 5-T9N., R- 10E., Gila and Salt River Baseline and Meridian, Gila County AZ. Gila Salt River Base and Meridian, Arizona.

To represent me re: any and all matters pertaining to the conduct of any and all business with any lawful authority or private individual or business, regarding the noted mining claims in the document.

X Virgil Baker Date: July 28, 2015

Virgil Baker As Principle

STATE OF Wyoming

COUNTY OF Platte

Virgil Baker personally appeared before me and acknowledged the execution of this Power of Attorney for the purposes set forth therein.

Dated: July 28, 2015

Shae L Evans, Notary Public

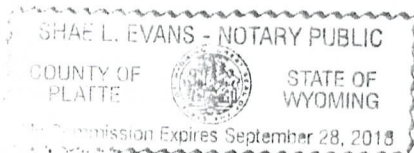

My Commission expires 9/28/2018

PHOENIX, ARIZONA  
2015 AUG 17 A 11:19  
RECEIVED  
PLM AZ STATE OFFICE

7-26-2015

"I Virgil Baker authorized and am aware that I am listed as a locator on the location notice for (AMC 430837). I have a bona fide interest in these claims and I located the claims independently, for my own self-interest and in good faith. I certify that these claims are in no way being located for the benefit of a company, corporation, or another individual in order to gain additional acreage they are not entitled to in accordance with the law."

Virgil Baker, As Principal



Address: 85 Forest Svc Rd633 Wheatland ,Wy 82201

STATE OF WYOMING

COUNTY OF PLATTE

Virgil Baker personally appeared before me and acknowledged the execution of the document for the purposes set forth herein.

Dated: July 28, 2015

Notary Public

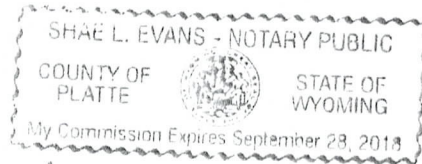
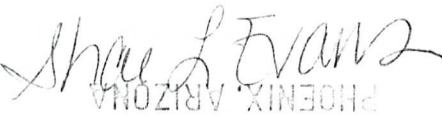

2015 AUG 17 A 11:19

RECEIVED  
1 M AZ STATE OFFICE

My Commission expires 9/28/2018

7-26-2015

**POWER OF ATTORNEY**

Richard Johnson the "Principal" of 17200 West Bell Rd. Lot # 1625, Surprise AZ., 85374... herewith appoints Patti K. Wooldridge of 1020 E. Saddle Butte St., Apache Junction, AZ., 85119 as their attorney in fact to act in the place and stead and with the same authority as "Principle" would have to do the following acts:

To act for me in the regard to the following: Mining Claim: GOLDDIGGERS 6 (AMC430837) Described as: East 1/2 of the NW 1/4 Section of Section 5-T9N., R-10E., Gila and Salt River Baseline and Meridian, Gila County AZ. Gila Salt River Base and Meridian, Arizona.

To represent me re: any and all matters pertaining to the conduct of any and all business with any lawful authority or private individual or business, regarding the noted mining claims in the document.

X Richard Johnson Date: 8/13/15

Richard Johnson, As Principle

STATE OF Arizona

COUNTY OF Pinal Maricopa

Richard Johnson personally appeared before me and acknowledged the execution of this Power of Attorney for the purposes set forth therein.

Dated: 8/13/15

Lynette Kowanetz

Notary Public

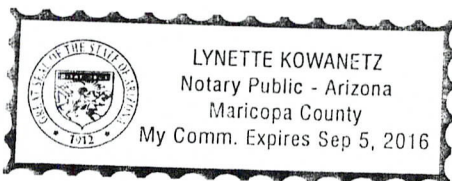

RECEIVED  
LIM AZ STATE OFFICE  
2015 AUG 17 A 11:19  
PHOENIX, ARIZONA



**NOTICE!!**

**These documents have been scanned!**

**Do not place un-scanned documents beneath this notice!**

**Do not remove this notice from this file!**

GPO Jacket No. 560-102  
Print Order 61540  
Rise Business Services, LLC  
Job=AZ15 5/9/2019



Box Number= AZ15028



Claim Begin-End: AMC430837-AMC430837

6 Location Notices-Amendments and Supporting Documents



AZ15028-11

AMC430583-AMC430889

# MINING CLAIM STATUS REPORT

Data Entered: 03/10/15 Rm

MTP Checked By: EG  
GEO Checked By: EG

LEAD SERIAL NUMBER: AMC 430837 thru AMC       

### NUMBER OF CLAIMS & TYPE:

LODE \_\_\_\_\_  
PLACER \_\_\_\_\_  
1 ASSOCIATION PLACER  
MILL SITE \_\_\_\_\_  
TUNNEL SITE \_\_\_\_\_

### CHARGES:

Location Fee @ \$37 = \$ 37  
Processing Fee @ \$20 = \$ 20  
Maintenance Fee @ \$155 = \$ 155  
3 Add'l Maint Fee for Assoc Placer = \$ 465  
**SUBTOTAL** \$ 677  
Other Fees \$ \_\_\_\_\_  
Other Fees \$ \_\_\_\_\_  
**TOTAL** \$ \_\_\_\_\_

TOTAL ACREAGE: 80 ac Per Claim  
(Placer Only)

NUMBER OF LOCATORS: 4

DOCUMENTS RECEIVED VIA: Over-the-Counter  Mail  TIMELY FILED: Yes  No

LEGAL DESCRIPTION: T 9N R 10E SEC 5  
T \_\_\_\_\_ R \_\_\_\_\_ SEC \_\_\_\_\_  
T \_\_\_\_\_ R \_\_\_\_\_ SEC \_\_\_\_\_  
T \_\_\_\_\_ R \_\_\_\_\_ SEC \_\_\_\_\_  
T \_\_\_\_\_ R \_\_\_\_\_ SEC \_\_\_\_\_

BLM  FOREST SERVICE  WILDERNESS AREA  SUBJ TO PL 359: Yes  No

SPLIT ESTATE: N/A  SX  PX  OTHER   
SRHA  Was proper Notice filed if located on SHRA Land? Yes  No

### RECONVEYED MINERALS ON BLM LAND REQUIRE OPENING ORDER FROM 1944 TO 1993:

Open to Entry On \_\_\_\_\_ N/A

COMMENTS/STATUS: VOID  PARTIALLY VOID  PVT MINERALS  WITHDRAWN LANDS   
OTHER

Claimant acknowledges that portions of the following claim(s) site(s) may be void or voidable.

Printed Name of Claimant \_\_\_\_\_ Signature of Claimant \_\_\_\_\_

\*\*\*\*\*FINAL ADJUDICATION\*\*\*\*\*

DATE 6/29/2015 INITIALS RM

LOCATION NOTICE FOR PLACER MINING CLAIM

Amendment BLM Serial # \_\_\_\_\_

NOTICE IS HEREBY GIVEN that the Gold digger 26  
\_\_\_\_\_ placer mining claim has been located by

VIRGIL BAKER whose current mailing

address is 6790 S. OAKMONT DR CHANDLER AZ  
PATTI WOOLDRIDGE 1020 E. SADDLE BUTTE #5249

APACHE JUNCTION

RICHARD JOHANSON 11250 EAST STATE ROUTE 69 #2126 DEWEY AZ. 86327

The general course of this claim is N to S and it is situated in GILA

County, Arizona. This claim is 2640 feet in length and 1320 feet in width.

80 Total Claim Acreage. This claim runs from the location monument on which this location notice is

posted at the SW corner of the claim approximately 2640 feet in a N direction to the

N end line and 1320 feet in a E direction to the NE end line. This claim is marked by four monuments, one at each corner of the claim.

The location monument on which this notice is posted is situated within Section 9N, Township

10 E, Range T9N R10E, Gila Salt River Base and Meridian, Arizona. This claim encompasses portions of the following legal subdivision(s) if located by legal subdivision or the following quarter section(s),

section(s), Township(s) and Range(s) East 1/2 of the NW 1/4 section of section 5 - T9N R10E,

Gila + Salt River BxM Mts County AZ, Gila Salt River Base and Meridian, Arizona.

The locality of this claim with reference to some natural object or permanent monument and additional information

(if any) concerning its locality are as follows: other locators Jerry Almas 29 Near Red Cascade Mt 5942

Jerry Kivela 42452 Liberty Ln, Phoenix 85048, BOB MONTERAS 4301 ATHERTON RD

BURTAS Mt 48519 The above information is shown on the attached map.

DATED AND POSTED on the ground this 6th day of April, 2015.

LOCATOR(s)  AGENT

Print Name(s) PATTI WOOLDRIDGE AGENT + LOCATOR

Signature(s) Patti Wooldridge

Form MCF102  
Revised July 2014

This form is available from the Arizona Geological Survey and may be reproduced.

BLM  
Date  
Stamp

PHOENIX, AZ

2015 APR -6 P 1:27

RECEIVED  
BLM AZ STATE OFFICE

AN0430837

Patti Woodruff

(C) 602-570-1493

(H) 480-288-6085



**MINING CLAIM MAP**

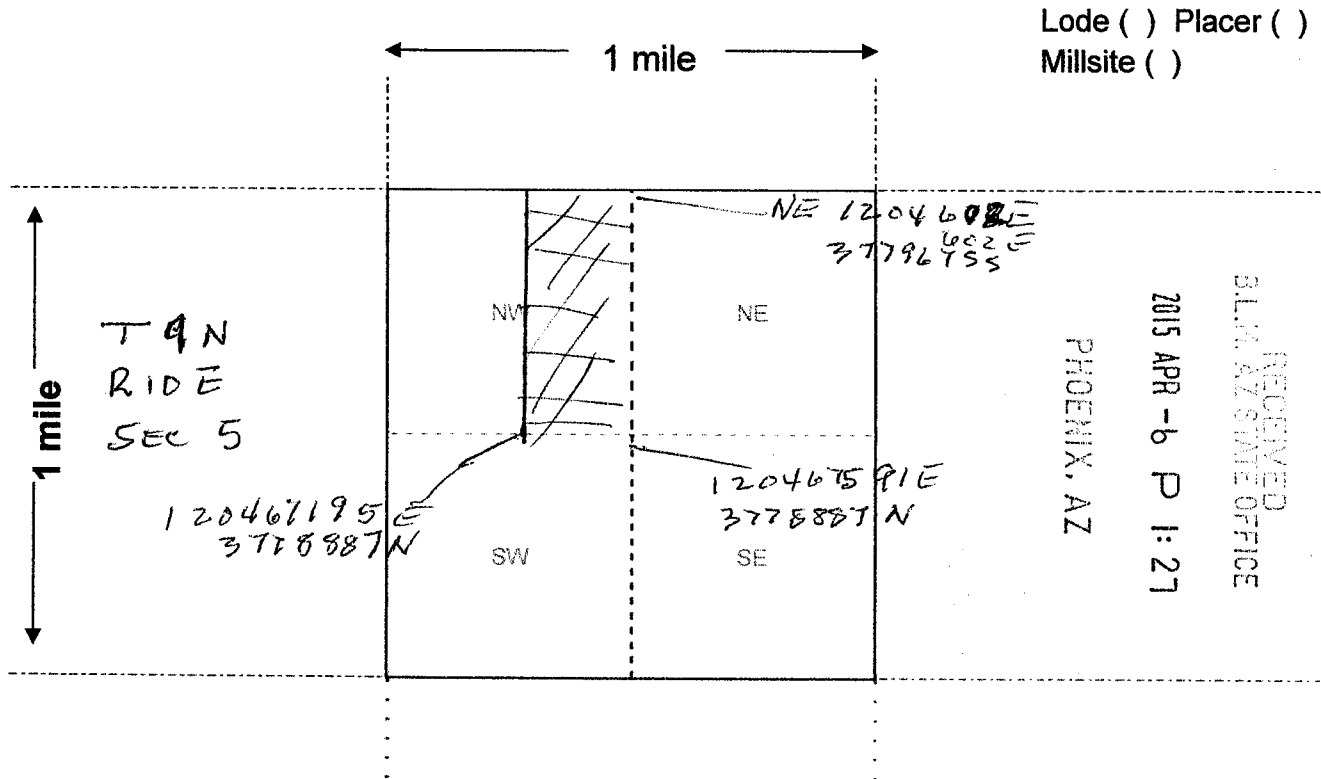

Scale: 1" = 2000 feet

1. The above map depicts the East 1/2 of NW 1/4 mining claim, which is located in Section (s) 5, Township 9 N, Range 10 E, Gila and Salt River Base and Meridian, \_\_\_\_\_ County, Arizona. Total claim acreage is 80

2. The type of corner and location monuments used are as follows: corner posts - green stakes - sign

3. The bearings and distances in degrees and feet between claim corners and to a public land survey monument are as depicted on the map.

4. If the claim is a placer or millsite claim with exterior limits conforming to legal subdivisions of the public survey, provide a legal description of the claim East 1/2 of NW 1/4 section of section 5 T9N R10E, Gila Salt River B+M Gila County Arizona

Form MCF100a  
Revised July 2014

DEPARTMENT OF INTERIOR  
BUREAU OF LAND MANAGEMENT

Input Parameters for Geographic Report with Land

System Id = CR

Admin State = AZ

Geo State =

Casetype Begins With

Case Disp Txt = AUTHORIZED, CANCELLED, EXPIRED, PENDING, REJECTED, RELINQUISHED, VOID, WITHDRAWN

Mer Twp Rng =

Section =

Mtrs = 14 0090N 0100E 005, 14 0090N 0100E 999

Commodity =

Commodity Txt =

Pending Org =

Pend Org Decode =

Total Rows Returned: 3



RUN TIME: 01:05 PM

UNITED STATES DEPARTMENT OF INTERIOR  
BUREAU OF LAND MANAGEMENT  
GEOGRAPHIC REPORT WITH LAND  
Sorted by Serial Number

RUN DATE: 04/06/2015  
Page 1 of 1

Adm State: AZ

Serial Number: AZA 028900  
Total Case Acres: 7,493.930

<u>Casetype</u>	<u>Case Disp</u>			<u>Sect</u>	<u>Sur Typ</u>	<u>Sur Num</u>	<u>Suff</u>	<u>Subdivision</u>	<u>Act Pend</u>
232170	AUTHORIZED	14	0090N	0100E	005	ALIQ LOTS		S2NE,SE; 1-2;	

Serial Number: AZA 036583  
Total Case Acres: 4.050

<u>Casetype</u>	<u>Case Disp</u>			<u>Sect</u>	<u>Sur Typ</u>	<u>Sur Num</u>	<u>Suff</u>	<u>Subdivision</u>	<u>Act Pend</u>
282107	AUTHORIZED	14	0090N	0100E	005	FF		PART;	





